

Employee Safety Manual

CONSTRUCTION SERVICES & SUPPLY, Inc.

Date: 05/12/2009

COMPANY POLICY LETTER

SAFETY AND HEALTH POLICY FOR CONSTRUCTION SERVICES & SUPPLY, INC. (CSSI).

The purpose of this policy is to develop a high standard of safety throughout all operations of CSSI.

We believe that each employee has the right to derive personal satisfaction from his/her job and the prevention of occupational injury or illness is of such consequence to this belief that it will be given top priority at all times.

It is our intention here at **CSSI** to initiate and maintain complete accident prevention and safety training programs. Each individual from top management to the working person is responsible for the safety and health of those persons in their charge and coworkers around them. By accepting mutual responsibility to operate safely, we will all contribute to the well being of personnel.

(Signature & Title)

Safety Program Outline

CSSI

Element 1 - Safety Orientation: Each employee will be given a safety orientation by the VP of Construction Services when first hired. The orientation will cover the following items:

A description of the accident prevention program:

- We have a formal written accident prevention program as described in WISHA regulations (WAC 296-155-110). It consists of this safety orientation, safety meetings as described in Element 2, and Self-inspections as outlined in Element 3.
- We also have basic safety rules that all employees must follow.
- Never do anything that is unsafe in order to get the job done. If a job is unsafe, report it to your supervisor or foreman. We will find a safer way to do that job.
- Do not remove or disable any safety device! Keep guards in place at all times on operating machinery.
- Never operate a piece of equipment unless you have been trained and are authorized.
- Use your personal protective equipment whenever it is required.
- Obey all safety warning signs.
- Working under the influence of alcohol or illegal drugs or using them at work is prohibited.
- Do not bring firearms or explosives onto company property.
- Horseplay, running and fighting are prohibited
- Clean up spills immediately. Replace all tools and supplies after use. Do not allow scraps to accumulate where they will become a hazard. Good housekeeping helps prevent accidents.
- *(Add any other basic safety rules that apply to your company. Delete any from the above list that do not apply to your business.)*

How and when to report injuries, including first aid kits and their locations:

- If you are injured or become ill on the job, report this to the VP of Construction Services.
- We require all supervisors and/or foremen to have first-aid/CPR training. ¹
- We have first aid qualified workers here but we do not have “designated” first-aiders. First aid at the job site is done on a Good Samaritan basis.
 - If first aid trained personnel are involved in a situation involving blood, they should:
 - Avoid skin contact with blood/other potentially infectious materials by letting the victim help as much as possible, and by using gloves provided in the first aid kit.
 - Remove clothing, etc. with blood on it after rendering help.
 - Wash thoroughly with soap and water to remove blood. A 10% chlorine bleach solution is good for disinfecting areas contaminated with blood (spills, etc.).

- Report such first aid incidents within the shift to supervisors (time, date, blood presence, exposure, names of others helping).
- **First aid kit locations at this jobsite include:**

Temperature Extremes

Workers subjected to temperature extremes, radiant heat, humidity, or air velocity combinations which, over a period of time, may produce physical illness. Protection by use of adequate controls, methods or procedures, or use of protective clothing will be provided to employees working in these conditions. Excessive exposure to heat is referred to as heat stress and excessive exposure to cold is referred to as cold stress.

Heat related illness (HRI) and cold-induced illnesses (Hypothermia/frostbite) are well known, recognized workplace hazards. All work operations involving exposure to temperature extremes, either humidity/heat extremes or cold extremes have the potential for inducing heat stress and heat related illnesses or cold stress resulting in frostbite or hypothermia, therefore, CSSI has developed a policy to address these issues. All employees will receive training relating to the causes and effects, as well as the personal and environmental factors that may lead to temperature extreme related illnesses. Each employee will be provided with training and materials that include but are not limited to:

- The chosen method or methods to assess the risk for HRI or cold stress.
- A section covering training elements to provide employees information on what the employer will do when working in extreme weather conditions.
- A section on first aid including how to identify HRI symptoms and cold stress systems. The proper first aid application for an individual that is suffering from HRI or cold weather illness, and procedures for summoning medical aid personnel.
- A section identifying where and how adequate drinking water will be supplied.

What to do in an emergency including how to exit the workplace:

- An evacuation map for the building is posted, it shows the location of exits, fire extinguishers, first aid kits, and where to assemble outside.

Fire Emergency

- A fire extinguisher or fire extinguishers will be covered as part of this orientation.
- If you discover a fire: ² Tell another person immediately. Call or have them call 911 and a supervisor.
- If the fire is small (such as a wastebasket fire) and there is minimal smoke, you may try to put it out with a fire extinguisher.
- If the fire grows or there is thick smoke, do not continue to fight the fire.
- Tell other employees in the area to evacuate.
- Go to the designated assembly point outside the building.

Add other emergency procedures ³

Identification of hazardous chemicals used at this location:

- Safe use and emergency actions to take following an accidental exposure.
- We use a limited number of chemicals. You will receive a separate orientation as part of our chemical hazard communication program on the hazards of these chemicals before you work with them or work in an area where they are used.

Use and care of required personal protective equipment (PPE): 4

- Some tasks in our company require an employee to wear PPE to protect against injury.
- You will be instructed by the VP of construction Services using the manufacturer's instructions on how to use and care for these PPE.

On-the-job training about what you need to know to perform the job safely:

- Before you are first assigned a task, VP of Construction Services will show you what to do along with safety instructions and required PPE.
- We have established safety rules and personal protective equipment (PPE) requirements based upon a hazard assessment for each task.
- Do not use equipment or attempt to do any of these tasks until you have received the required training and PPE.

Safety Meetings and Self-Inspections

• Element 2 - Employee Safety Meetings

- At the beginning of each job and at least weekly thereafter.
- Review of any walk-around safety inspections conducted since the last safety meeting.
- Review of any citation to assist in correction of hazards.
- Evaluation of any accident investigations conducted since the last meetings to determine if the cause of the unsafe acts or unsafe conditions involved were properly identified and corrected.
- Document attendance and other subjects discussed.
- *Maintain records for one year.*

• Element 3 – Self-inspections

- At the beginning of each job, and at least weekly thereafter.
- Include one member of management and one employee, elected by the employees, as their authorized representative.
- Document walk-around safety inspection.
- *Maintain records until the completion of the job.*

Safety Disciplinary Policy

CSSI believes that a safety and health Accident Prevention Program is unenforceable without some type of disciplinary policy. Our company believes that in order to maintain a safe and healthful workplace, the employees must be cognizant and aware of all company, State, and Federal safety and health regulations as they apply to the specific job duties required. The following disciplinary policy is in effect and will be applied to all safety and health violations.

The following steps will be followed unless the seriousness of the violation would dictate going directly to Step 2 or Step 3.

1. A first time violation will be discussed orally between company supervision and the employee. This will be done as soon as possible.
2. A second time offense will be followed up in written form and a copy of this written documentation will be entered into the employee's personnel folder. Time off without pay (3 day minimum).

3. A third time violation will result in termination.

If an employee of this company knowingly and willingly violates any of the safety rules or procedures, or puts his/her self in an imminent danger situation, the employee will be immediately discharged.

General Safe Work Practices for Construction

Personal Protective Equipment

- Suitable clothing must be worn; long pants, at least short-sleeved shirts and adequate foot wear.
- Hard hats, safety glasses or goggles must be used when a potential hazard exists. (Safety glasses must be ANSI Z87 or Z87.1 approved).
- Hearing protection (earplugs or earmuffs) must be used in high noise areas.
- Gloves (as needed).

Housekeeping

- Always store materials in a safe manner. Tie down or support materials if necessary to prevent falling, rolling, or shifting.
- Shavings, dust scraps, oil or grease should not be allowed to accumulate. Good housekeeping is a part of the job.
- Trash piles must be removed as soon as possible. Trash is a safety and fire hazard.
- Immediately remove all loose materials from stairs, walkways, ramps, platforms, etc.
- Do not block aisles, traffic lanes, fire exits, gangways, or stairs.

Other general safe work practices

- Avoid shortcuts – use ramps, stairs, walkways, ladders, etc.
- Do not remove, deface or destroy any warning, danger sign, or barricade, or interfere with any form of accident prevention device or practice provided for your use or that is being used by other workers.
- Get help with heavy or bulky materials to avoid injury to yourself or damage to material.

- Do not use tools with split, broken, or loose handles, or burred or mushroomed heads. Keep cutting tools sharp and carry all tools in a container.
- Know the correct use of hand and power tools. Use the right tool for the job.

Fall protection

- Fall hazards of 10 feet or more will be outlined and addressed in our jobsite fall protection work plan.
- Fall hazards of less than 10 feet will be protected by covers, guardrails or other methods and will be addressed in our self-inspections and safety meetings.
- Standard guardrails must be erected around all floor openings and open-sided surfaces. Contact your supervisor for the correct specifications.

Electrical

- Ground-fault circuit interrupters (GFCI) will be used when ever possible.
- Electric cords will be inspected daily and repaired or replaced as necessary.
- Do not operate any power tool or equipment unless you are trained in its operation.
- Use tools only for their designed purpose.

Ladder safety

- Inspect before use for physical defects.
- Ladders are not to be painted except for numbering purposes.
- Do not use ladders for skids, braces, workbenches, or any purpose other than climbing.
- When you are ascending or descending a ladder, do not carry objects that will prevent you from grasping the ladder with both hands.
- Always face the ladder when ascending and descending.
- If you must place a ladder over a doorway, barricade the door to prevent its use and post a warning sign.
- Only one person is allowed on a ladder at a time.
- Do not jump from a ladder when descending.
- All joints between steps, rungs, and side rails must be tight.
- Safety feet must be in good working order and in place.

- Rungs must be free of grease and/or oil.

Stepladders

- Do not place tools or materials on the steps or platform of a stepladder
- Do not use the top two steps of a stepladder as a step or stand.
- Always level all four feet and lock spreaders in place.
- Do not use a stepladder as a straight ladder.

Straight type or extension ladders

- All straight or extension ladders must extend at least three feet beyond the supporting object when used as an access to an elevated work area.
- After raising the extension portion of a two or more stage ladder to the desired height, check to ensure that the safety dogs or latches are engaged.
- All extension or straight ladders must be secured or tied off at the top.

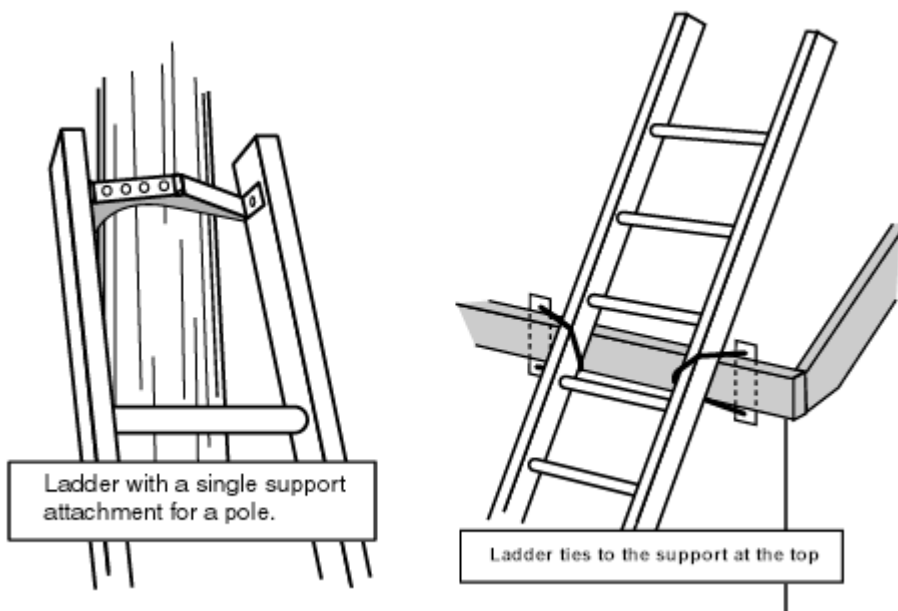

- All ladders must be equipped with safety (non-skid) feet.

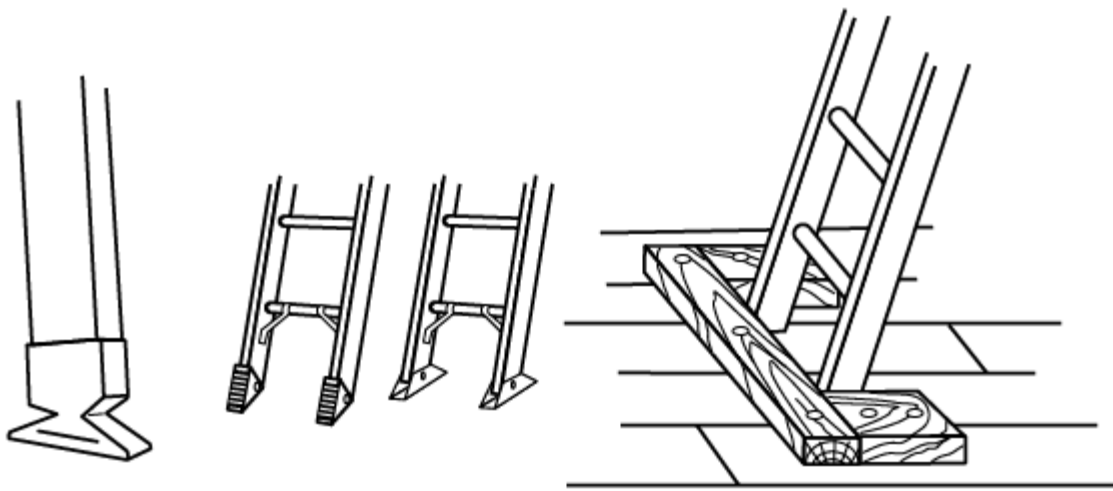

Rubber Safety Feet	Spikes	Cleats Nailed to the Floor
Ladders with supports on the bottom.		

- Portable ladders must be used at such a pitch that the horizontal distance from the top support to the foot of the ladder is about one-quarter of the working length of the ladder.

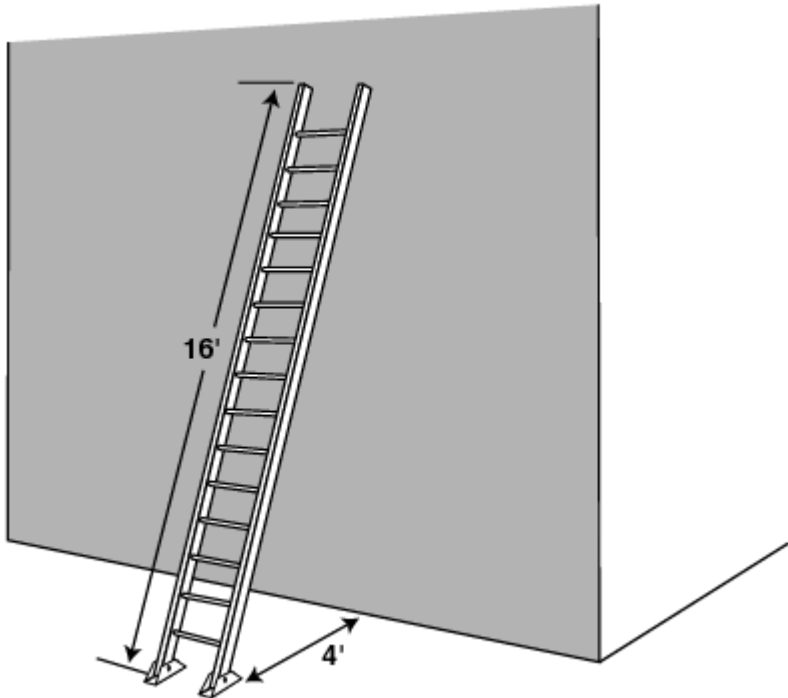

For other rules and regulations regarding Portable Ladders, please refer to Safety Standard, WAC 296-876. For other rules and regulations regarding Fixed Ladders & Stairways, please refer to Part J of the Safety Standard WAC 296-155.

Trenching and Excavating

1. The determination of the angle of repose and design of the supporting system shall be based on careful evaluation of pertinent factors, such as:
 - a. Depth and/or cut/soils classification
 - b. Possible variation in water content of the material while excavation is open
 - c. Anticipated changes in materials from exposure to air, sun, water, or freezing
 - d. Loading imposed by structures, equipment, or overlaying or stored material
 - e. Vibration from equipment, blasting, traffic, or other sources

Approximate Angle of Repose For sloping of sides of excavations

Note:
Clays, silts, loams or non-homogenous soils require shoring and bracing
The presence of ground water requires special treatment

Solid rock and compact shale (90°)	Compacted angular gravels, glacial till ½:1 (63°26')	Recommended slope For Average soils 1:1 (45°)	Compacted sharp sand 1 ½:1 (33°41')	Well rounded loose sand 2:1 (26°34')
------------------------------------	--	---	-------------------------------------	--------------------------------------

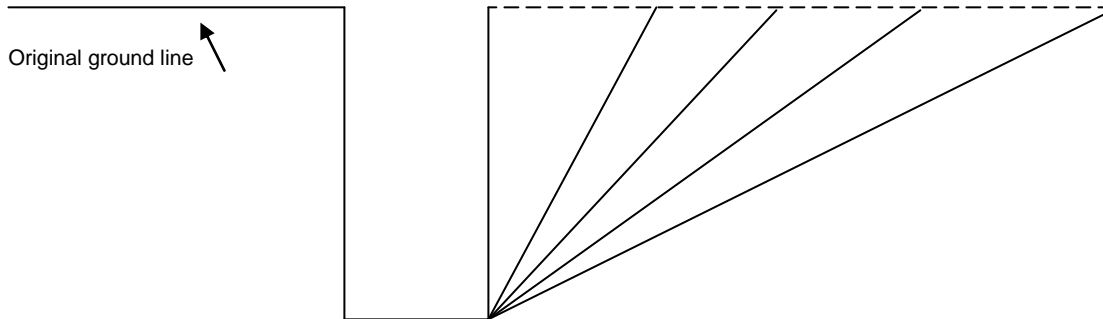

2. Walkways or bridges with standard railings **must be provided** when employees or equipment are required to cross over excavations.
3. The walls and faces of all excavations in which employees are exposed to danger from moving ground **must be guarded** by a shoring system, sloping of the ground, or some other equivalent means.
4. **No person must be permitted** under loads handled by power shovels, derricks, or hoists.
5. **All employees must be protected** with personal protective equipment for the protection of the head, eyes, respiratory system, hands, feet, and other parts of the body.

For other rules and regulations regarding trenching and excavating, please refer to Part N of the Construction Safety Standard, WAC 296-155.

Scaffold Safety Rules

1. General

Before starting work on a scaffold, inspect it for the following:

- a. Are guardrails, toeboards, and planking in place and secure?
 - b. Are locking pins at each joint in place?
 - c. Are all wheels on moveable scaffolds locked?
2. Do not attempt to gain access to a scaffold by climbing on it (unless it is specifically designed for climbing – always use a ladder).
 3. Scaffolds and their components must be capable of supporting four times the maximum intended load.
 4. Any scaffold, including accessories such as braces, brackets, trusses, screw legs, ladders, etc., damaged or weakened in any way, must be immediately repaired or replaced.
 5. Scaffold planks must extend over their end supports not less than 6 inches or more than 12 inches, unless otherwise specifically required.
 6. Scaffold platforms must be at least 18 inches wide unless otherwise specifically required or exempted.
 7. Where persons are required to work or pass under the scaffold, scaffolds shall be provided with a screen between the toeboard and guardrail, extending along the entire opening. The screen must be made of No. 18 gauge U.S. Standard wire, ½ inch mesh or equivalent protection.
 8. All scaffolds must be erected level and plumb, and on a solid footing.
 9. Do not change or remove scaffold members unless authorized.
 10. Do not allow workers to ride on a rolling scaffold when it is being moved. Remove or secure all materials and tools on deck before moving.
 11. Do not alter any scaffold member by welding, burning, cutting, drilling, or bending.

For other rules and regulations regarding scaffolding, please refer to Part J of the Construction Safety Standard, WAC 296-155.

Motorized vehicles and equipment

1. Do not ride on motorized vehicles or equipment unless a proper seat is provided for each rider.
2. Always be seated when riding authorized vehicles (unless they are designed for standing).
3. Do not operate any motorized vehicle or equipment unless you are specifically authorized to do so by your supervisor.
4. Always use your seat belts in the correct manner.
5. Obey all speed limits and other traffic regulations.
6. Always be aware of pedestrians and give them the right-of-way.
7. Always inspect your vehicle or equipment before and after daily use.
8. Never mount or dismount any vehicles or equipment while they are still in motion.
9. Do not dismount any vehicle without first shutting down the engine, setting the parking brake and securing the load.
10. Do not allow other persons to ride the hook or block, dump box, forks, bucket or shovel of any equipment.
11. Each operator must be knowledgeable of all hand signals and obey them.
12. Each operator is responsible for the stability and security of his/her load.

Forklift safety

Prior to performing work on or around Powered Industrial Trucks (forklifts) employees will receive training in: (See State of Washington – Forklift Safety Guide).

- Forklift safety hazards
- Types of forklifts (powered industrial trucks)
- Forklift operator training requirements

For other rules and regulations regarding motor vehicles, mechanized equipment and marine operations, please refer to Part M of the construction Safety Standard, WAC 296-155.

You are at the end of the Sample Employee Safety Program. Please be sure that you have added all the required information to make it specific to your business. If you have any further information to add, please do so. Otherwise delete this message.

¹ Tailored to specify availability of the first aid provider component of first aid facilities.

²Tailored to specify limits of employee involvement in fire fighting and provide specific evacuation instructions.

³ Tailored to specify emergency procedures (such as location of emergency shut-off) and assign responsibility for this task.

⁴ Tailored to specify what types of PPE (Personal Protective Equipment) are required in this facility and incorporate manufacturer's instructions for use and care into the program.

Job Orientation Guide

Company: CSSI
 Trainer:
 Date

Employee:
 Hire Date:
 Position:

This checklist is a guideline for conducting employee safety orientations for employees new to CSSI. Once completed and signed by both supervisor and employee, it serves as documentation that orientation has taken place.

	Date	Initials
1. Explain the company safety program, including:		
Orientation	_____	_____
On-the-job training	_____	_____
Safety meetings	_____	_____
Accident investigation	_____	_____
Disciplinary action	_____	_____
2. Use and care of personal protective equipment, (Hard hat, fall protection, eye protection, etc.)	_____	_____
3. Line of communication and responsibility for immediately reporting accidents.		
A. When to report an injury	_____	_____
B. How to report an injury	_____	_____
C. Who to report an injury to	_____	_____
D. Filling out accident report forms	_____	_____
4. General overview of operation, procedures, methods and hazards as they relate to the specific job	_____	_____
5. Pertinent safety rules of the company and WISHA	_____	_____
6. First aid supplies, equipment and training		
A. Obtaining treatment	_____	_____
B. Location of Facilities	_____	_____
C. Location and names of First-aid trained personnel	_____	_____
7. Emergency plan		
A. Exit location and evacuation routes	_____	_____
B. Use of fire fighting equipment (extinguishers, hose)	_____	_____
C. Specific procedures (medical, chemical, etc.)	_____	_____
8. Vehicle safety	_____	_____
9. Personal work habits		
A. Serious consequences of horseplay	_____	_____
B. Fighting	_____	_____
C. Inattention	_____	_____
D. Smoking policy	_____	_____
E. Good housekeeping practices	_____	_____
F. Proper lifting techniques	_____	_____

NOTE TO EMPLOYEES: Do not sign unless ALL items are covered and ALL questions are satisfactorily answered.

The signatures below document that the appropriate elements have been discussed to the satisfaction of both parties, and that both the supervisor and the employee accept responsibility for maintaining a safe and healthful work environment.

Date: _____ Supervisor's Signature: _____

Date: _____ Employee's Signature: _____

FALL PROTECTION WORK PLAN

COMPANY: _____ DATE: _____
SITE ADDRESS: _____
REPORT PREPARED BY: _____ TITLE: _____

- 1) SPECIFIC WORK AREA: _____
 - 2) ACTIVITIES: _____
 - 3) IDENTIFY ALL FALL HAZARDS IN THIS AREA: _____
- _____

4) CHECK THE METHOD OF FALL RESTRAINT OR ARREST TO BE UTILIZED:

- | | | |
|--|--|--|
| <input type="checkbox"/> STANDARD GUARDRAIL | <input type="checkbox"/> FULL BODY HARNESS | <input type="checkbox"/> SCISSOR LIFT |
| <input type="checkbox"/> SECURED TO EXISTING STRUCTURE | <input type="checkbox"/> TIE-OFF POINT CAPABLE OF 5000 LB/PERSON | <input type="checkbox"/> BOOM LIFT |
| <input type="checkbox"/> SHOCK ABSORBING LANYARD | <input type="checkbox"/> RETRACTABLE LANYARD | <input type="checkbox"/> FORKLIFT BASKET |
| <input type="checkbox"/> SCAFFOLD W/GUARDRAIL | <input type="checkbox"/> OTHER (SPECIFY) | |
| <input type="checkbox"/> WARNING LINE | <input type="checkbox"/> WARNING LINE & SAFETY MONITOR (See WAC 296-155-24521) | |

- 5) DESCRIBE PROCEDURES FOR ASSEMBLY, MAINTENANCE, INSPECTION AND DIASSEMBLY OF THE SYSTEM (IF ADDITIONAL SPACE IS REQUIRED, COMPLETE ON THE BACK OR THIS FORM OR ATTACH A SEPARATE SHEET.)
- _____

- 6) DESCRIBE PROCEDURES FOR HANDLING AND SECURING TOOLS, EQUIPMENT AND MATERIALS AND FOR PROVIDING OVERHEAD PROTECTION FOR WORKERS (IF ADDITIONAL SPACE IS REQUIRED, COMPLETE ON THE BACK OF THIS FORM OR SEPARATE SHEET):
- _____

- 7) DESCRIBE THE METHOD FOR PROMPT, SAFE REMOVAL OF INJURED WORKER(S):
(Calling 911 is not sufficient as a means of rescue)
- _____

- 8) I CERTIFY THAT I HAVE RECEIVED FALL PROTECTION ORIENTATION INCLUDING THE MATERIAL COVERED IN THIS FALL PROTECTION WORK PLAN.

EMPLOYEE NAME:

DATE:

Walk-around Safety Inspection

- Power lines:** Minimum 10' clearance / insulate – de-energize, under 50 kw; over 50 kw – refer to Chapter 155
- Trench/excavation:** Any trench four feet or more must be sloped, shored or braced
- Guardrails:** Any opening four feet or more above ground level must be guarded
- Standard guardrail:** Top rail = 39" to 45" above working surface. Midrail = halfway between top rail and floor. Toeboard = 4".
- Scaffold:** Fully planked
- Scaffold:** Fall protection provided if fall hazards over 10 feet exist
- Stairs:** Four or more risers must have handrails
- Fall protection:** Any exposure to fall hazards of 10' or greater must be eliminated by the use of safety harness/belt, lanyard or lifeline, horizontal lines, or cantenary lines. Positive fall restraint/protection must be utilized at all times. Two lanyards may be necessary at the beam/upright traverse points. No exposure at any time is allowed.
- Fall protection work plan:** Job specific, in writing; available on-site for all fall hazards above 10'.
- Open belts and pulleys, chains and sprockets, points of operation** must be guarded to prevent accidental contact. Air compressors and electric motor pulleys are the most common hazards.
- Radial saws:** Cutting head must return easily to start position when released; blade must not extend past the edge of the worktable; off/on switch should be at front of operator's position.
- Table saws:** Upper hood guard; anti-kickback, push stick, belt and pulley guarded
- Circular saws:** Blade guard instantly returns to covering position
- Never wedge or pin a guard.**
- Ladders:** Extended 36" above landing and secured to prevent displacement
- Floor holes/openings:** Covered and secured; be sure no tripping hazards in the area.
- Extension cords/electric power tools:** Marked/covered by Assured Grounding Program
- Clothing:** Minimum of short sleeve shirts, long pants, and substantial footwear; no recreational shoes
- Hard hats:** readily accessible at all times; worn when overhead hazard exists
- Oxygen/acetylene storage areas:** Cylinders chained and separated
- Personal protective equipment:** Head, eye, ear, respiratory, and leg protection – high visibility vests when required
- Housekeeping:** Workers are responsible for their own area of exposure
- First aid/fire extinguishers:** Available and readily accessible

Other hazards observed: _____

Supervisor's signature

Date

Employee's signature

Date

Equipment Safety Inspection Checklist

Date: _____

Project: _____

Equipment: _____

All guards and fenders	_____	OK	_____	Needs Repair
Brakes	_____	OK	_____	Needs Repair
Lights – front, rear, side, dash	_____	OK	_____	Needs Repair
Back-up alarm – horn	_____	OK	_____	Needs Repair
Ladders, stairs, hand holds	_____	OK	_____	Needs Repair
ROPS (Roll-over protection)	_____	OK	_____	Needs Repair
Seat belts	_____	OK	_____	Needs Repair
Fire extinguisher	_____	OK	_____	Needs Repair
Glass	_____	OK	_____	Needs Repair
Tires	_____	OK	_____	Needs Repair
Electrical cords	_____	OK	_____	Needs Repair
Ground fault circuit interrupters	_____	OK	_____	Needs Repair
Electrical hand tools	_____	OK	_____	Needs Repair
Powder actuated tools	_____	OK	_____	Needs Repair
Condition of pneumatic hand tools	_____	OK	_____	Needs Repair

Other Items Checked:

Oil level and leaks	_____	OK	_____	Needs Repair	_____	Add	_____	Change
Hydraulic oil level and leaks	_____	OK	_____	Needs Repair	_____	Add	_____	Change
Anti-freeze level and leaks	_____	OK	_____	Needs Repair	_____	Add	_____	Change
Fuel level and leaks	_____	OK	_____	Needs Repair	_____	Add	_____	Change
First aid kit	_____	OK	_____	Needs Repair	_____	Add	_____	Change

Repaired by: _____

Checked by: _____

Department of Labor – OSHA Services

Framing Emphasis Checklist - Safety

Employer _____

Report Number: _____

CSHO Name: _____

Date of inspection: _____

		YES	NO	N/A
CONTRACTOR REGISTRATION				
Did employer have valid contractor's Registration?	Lic #: _____			
FALL PROTECTION				
Is fall protection used when exposed to 10' fall hazard?	155-24510			
Are fall protection anchorage points installed properly?	155-24510(2)(a)(ix)			
Is fall protection work plan available and implemented?	155-24505(1)			
LADDERS / STAIRWAYS				
Stairway installed before 2 nd floor studs raised?	155-477(1)(f)(i)			
Guardrail and handrail on stairways with 4 or more risers?	155-477(3)(a)(i)			
Ladders extend 3 ft beyond upper landing?	876-40030			
Ladders used for purpose they were designed for?	876-40005			
Top of ladder used as step?	876-40050			
Defective ladder marked and removed from service?	876-30005			
Ladder/stairway safety training program implemented?	876-50005			
GUARDING				
Hand-held power circular saws properly guarded?	155-370(2)			
Table saws properly guarded?	155-370(3)(a)			
Radial saws properly guarded?	155-370(4)(a)			
Power miter saws properly guarded?	155-370(7)			
Pneumatic nailer/stapler have safety device on muzzle?	155-360 (2) (c)			
STRUCTURE CONSTRUCTION				
Walls braced to prevent collapse?	155-035(8)			
Scaffolds fully planked and guarded?	874-20008 & 874-20052			
Floor openings guarded (12" or more)?	155-505(4)(a)			
Wall openings guarded by standard railing or equivalent?	155-505(5)(a)			
Open sided surfaces guarded by standard railing or equivalent?	155-505(6)(a)			
Stair or ramp provided for break in elevation >19"?	155-476(1)			
Ramp used for access is at least 18" wide?	155-515(1)			
PERSONAL PROTECTIVE EQUIPMENT (PPE)				
Individual hard hats available on site?	155-205(2)			
Hard hats used when exposed to flying or falling objects?	155-205(3)			
Eye protection worn?	155-215(1)(a) & 155-350 (3)			
Suitable clothing -short sleeved shirt and long pants worn?	155-200(2)(a)			
Proper footwear worn?	155-212			
Is leg protection used during chainsaw usage?	155-211			

ELECTRICAL				
Extension cords with ground pin?	155-447(6)(f)			
Extension cords free of improper splices?	155-449(7)(b)(iii)			
Multi-outlet J-Box are waterproof?	155-449(1)(a)(iii)			
GFCI or assured grounding program?	155-447 (2) (a) (i)			
RELATED PROGRAM REQUIREMENTS				
Is the APP tailored to the business and hazards involved?	155-110 (2)			
Does the employer provide safety orientations?	155-110 (3)			
Is the APP outlined in written format?	155-110 (4)			
Is a Crew Leader-Crew Safety meeting held at beginning of job & weekly thereafter?	155-110(5) (a)			
Are safety meetings tailored to the operations?	155-110 (5) (b)			
Are safety meetings documented?	155-110 (6) (d) & (e)			
Are safety walk-around inspections conducted at the beginning of the job and weekly thereafter?	155-110 (9) (a)			
Are walk-around inspections documented and available for inspection?	155-110 (9) (b)			
Do employees work with hazardous chemicals/materials?				
Is there a hazard communication program that is written and implemented?	800-17005			
Is there a Chemical Inventory for chemicals on-site?	800-17010			
Is there an MSDS for each hazardous product?	800-17015			
Are employees provided HAZCOM training?	800-17030			
FIRST-AID				
Are first-aid supplies available on-site?	800-15020			
Is there a first-aid trained person or persons on site?	155-120(2)			
Are crew leaders and supervisors first aid trained?	155-120(3)			
HOUSEKEEPING				
Is proper housekeeping maintained at the jobsite?	155-020 (1) through (12)			
SANITATION				
*Adequate supply of potable water provided?	155-140(1)(a)			
*Toilets provided and maintained at jobsite?	155-140(4)(b) & 155-140 (4) (d)			

* Does not apply to mobile crews or normally unattended work locations per WAC 296-155-140 (1) (g) & (h). Mobile crew is defined as “A work crew that routinely moves to a different work location periodically. Normally a mobile crew is not at the same location all day.”

This emphasis checklist outlines fundamental requirements and is not inclusive of all safety and health requirements for employers in the construction industry.

Hazard Communication checklist

1. Have we prepared a list of all the hazardous chemicals in our workplace?
2. Are we prepared to update our hazardous chemical list?
3. Have we obtained or developed a material safety data sheet for each hazardous chemical we use?
4. Have we developed a system to ensure that all incoming hazardous chemicals are checked for proper labels and data sheets?
5. Do we have procedures to ensure proper labeling or warning signs for containers that hold hazardous chemicals?
6. Are our employees aware of the specific information and training requirements of the Hazard Communication Standard?
7. Are our employees familiar with the different types of chemicals and the hazards associated with them?
8. Have our employees been informed of the hazards associated with performing non-routine tasks?
9. Are employees trained about proper work practices and personal protective equipment in relation to the hazardous chemicals in their work area?
10. Does our training program provide information on appropriate first aid, emergency procedures, and the likely symptoms of overexposure?
11. Does our training program include an explanation of labels and warnings that are used in each work area?
12. Does the training describe where to obtain data sheets and how employees may use them?
13. Have we worked out a system to ensure that new employees are trained before beginning work?
14. Have we developed a system to identify new hazardous chemicals before they are introduced into a work area?
15. Do we have a system for informing employees when we learn of new hazards associated with a chemical?

Written Hazard Communication Program

General:

It is the Policy of CSSI to provide and maintain a safe and healthy workplace for all employees including those who work with potentially hazardous chemicals. This written program will be posted and available 24 hours a day, seven days a week at the following locations:

1. 116 S. Piney Rd. #204, Chester, MD 21619

If you work with or around potentially hazardous chemicals, this program affects you. The HAZARD COMMUNICATION STANDARD is intended to inform you of any potential chemical hazards from products you may come in contact with at this facility.

Container Labeling:

All containers of chemical products received at this company and all containers used as secondary containers will contain a label listing their hazards, both physical and health hazards. If the label is missing contact the VP of Construction Services so that he may determine what the product is that has been received, and where it should be stored. **DO NOT ATTEMPT TO USE ANY CHEMICAL THAT IS NOT READILY IDENTIFIABLE.**

Material Safety Data Sheets:

The VP of Construction Services or Job Project Manager has the MSDS's on file from the various chemical manufacturers for all hazardous chemicals used in connection with this workplace. The MSDSs list, in English, information available about any particular chemical: health hazards, emergency and first aid procedures, how the chemical could enter the body, the safe handling and use of the chemical, name of manufacturer, etc. The MSDS file may be found in these locations:

1. 116 S. Piney Rd., Chester, MD 21619
2. Jobsite field office

Employee Training and Information:

The VP of Construction Services will provide training to all employees and new hires on the proper use of hazardous chemicals and potential hazards. They will be responsible for providing the following informational training to all employees:

1. Hazardous chemicals present in the workplace.
2. Location of various chemicals. What to use. What to avoid.
3. Emergency procedures in case of contact with hazardous chemicals.
4. How to read the labels.
5. Location of the MSDS files and how to read the MSDS.
6. Non-routine tasks that may be encountered.
7. Symptoms of overexposure and personal protective measures to be used.

Hazardous Materials Inventory List:

Examples: acids, aerosols, battery fluids, catalysts, caustics, cleaning agents, degreasing agents, flammables, fuels, fungicides, industrial oils, insecticides, herbicides, office copier chemicals, pesticides, surfactants, solvents, wood preservatives.

Per jobsite, see individual jobsite inventory lists located at jobsite field office